

REAR BEARING COVER AND FILTER ASSEMBLY

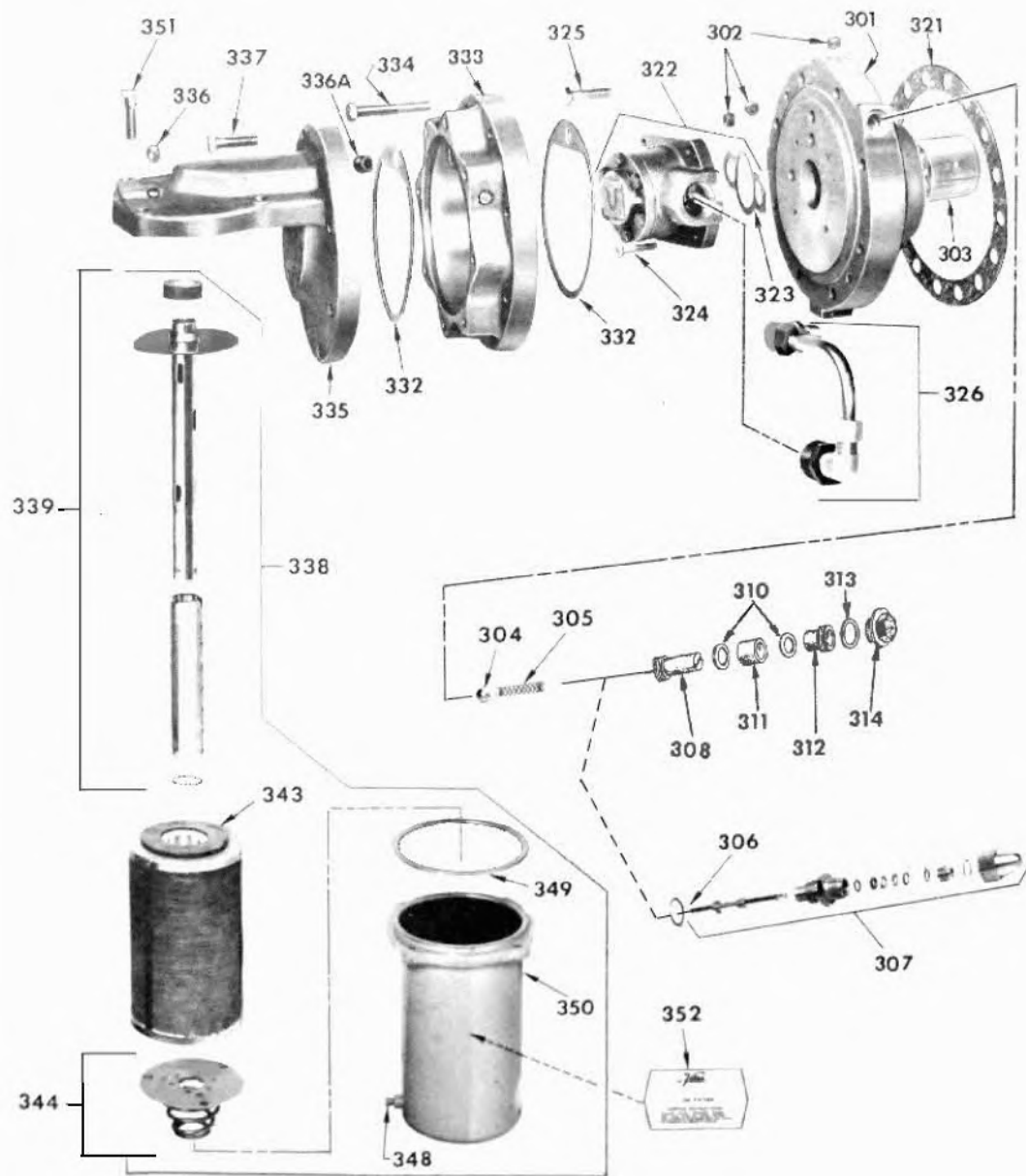

ITEM	DESCRIPTION	VILTER PART NUMBERS	
		QNTY	Models 300 series
304,305,308 thru 314, 321, 323	Rear Bearing Housing Assembly Kit	1	Kit 1002
301 thru 314	Rear Bearing Housing Assembly	1	A33149A
301	Housing, Rear Bearing	1	33149A**
302	Plug, Steel Hex Socket Head Pipe 3/8"	3	2606D
303	Bearing Crankshaft	1	33624A
304	Ball, Steel 5/8	1	13155K
305	Spring, Oil Relief	1	31048F
306	Gasket, Valve Body	1	11325A
307	Adjustable Oil Relief Valve Assembly	1	A35034A
308	Stem, 300 Oil Relief Valve	1	31048C
310	Washer	2	31048D
311	Packing Set, Valve	1	31048E
312	Nut	1	31048A
313	Gasket, Valve Cap	1	30651C
314	Valve Cap, Oil Relief	1	17355A
321	Gasket, Rear Bearing Housing	1	33652A
322	Oil Pump & Gasket Assembly	1	A33683A
323	Gasket, Oil Pump Mounting	1	33732A
324	Screw, Hex Head Cap 5/16" x 1" lg.	4	1047W
326	Pump Discharge Connection Assembly	1	A35067A
332	Gasket Adapter Filter Head	2	33943A
333	Adapter, Filter Head	1	33177B
334	Screw, Hex Head Cap 1/2" x 3/4"	8	13153M
335	Cover, Oil Pump & Filter Head	1	34463A
337	Screw, Hex Head Cap 1/2" x 1 1/4"	8	13153F
338	Filter Assembly (complete)	1	A35240A
339	Spool Assembly w/Bypass Relief	1	1448U
343	Recharge (Gasket #349 included)	1	1448C
344	Pressure Plate Assembly	1	1448M
350	Filter Shell w/ Bolt Ring	1	A34623A
351	Screw Head	4	2796DM
352	Instruction Plate	1	40680AT